

A DURAVANT COMPANY

Efficiency Through Innovation

# Parcel Singulator

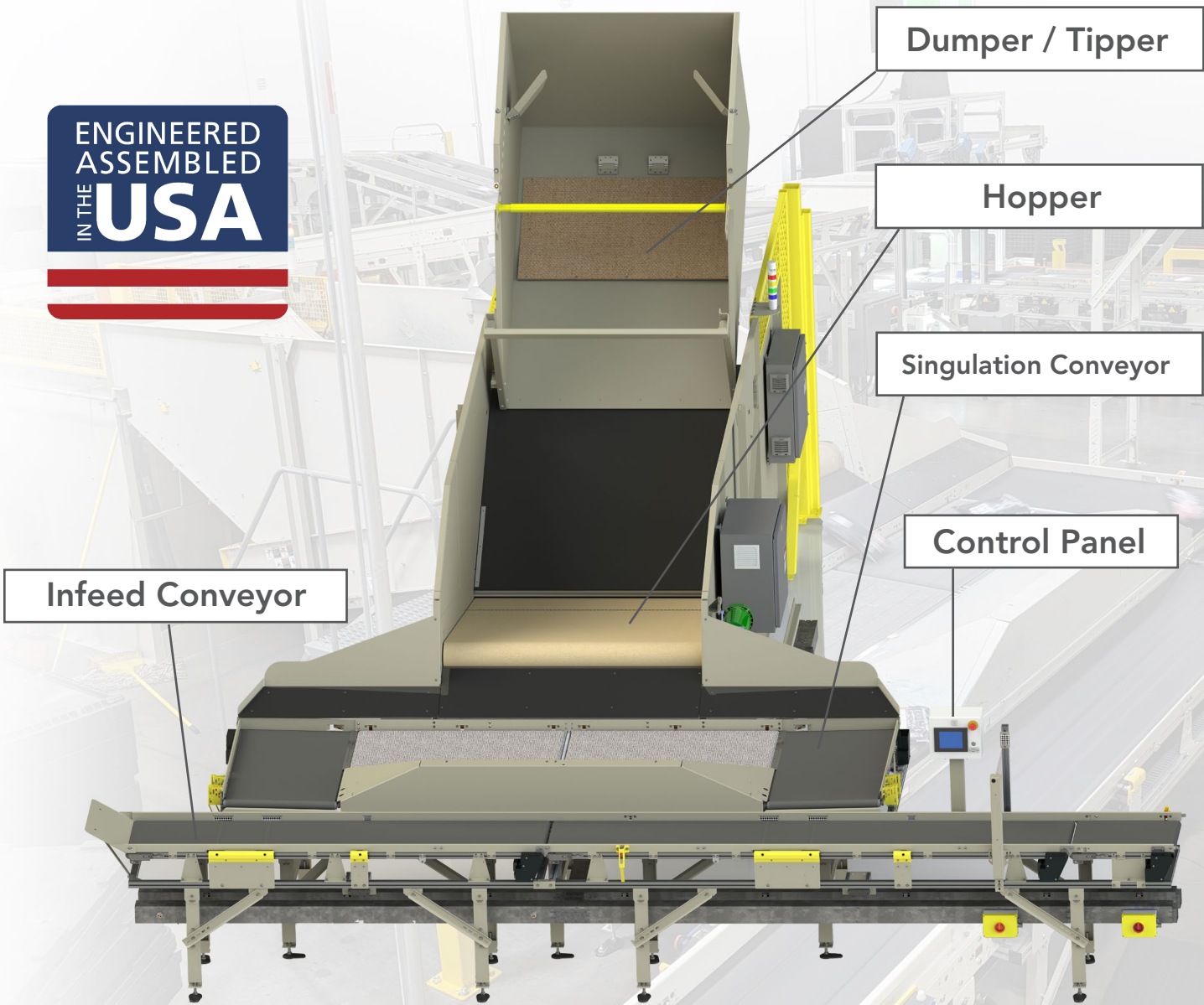
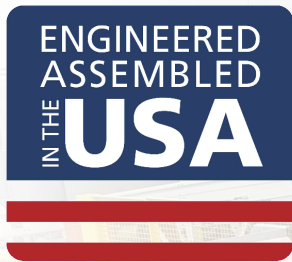

# NPI's Parcel Singulator

## Convert Bulk into Singulated Flow

Converting bulk into singulated flow has always been one of the most challenging aspects for feeding automated parcel processing solutions. Historically, there have been two options; either a manual and time consuming approach or a very large footprint automated solution with an extremely high price tag.

To solve this challenge, NPI's patented Parcel Singulator is capable of production flows of up to 10,000 PPH and handling a wide array of product types from polybags to boxes. The automated design also allows for the system to be operated with either one or two operators depending on work flow requirements.

## Versatile Options & Modes

The NPI Parcel Singulator includes a automatic singulation table, independent power control panel, PLC and NPI's touch screen operator control panel. Additional options include a dumper to discharge gaylords, pallets, or carts. It can be used to feed to a single singulation lane or split the load between two singulation lanes by smart-sensing available space on each lane and directing product flow appropriately.

The Parcel Singulator can run in a variety of different modes that allow for optimum singulation, based on product type. This can include combinations of fast automatic singulation, slow automatic singulation and a manual pull mode. Programmable options on the touch screen operator control panel allow employees to easily switch between modes based on product type to optimize flow.



- At position 1, the operator selects mode with control panel to optimize flow
- A dumper at position 2 is used to empty parcels out of a container directly into a hopper at position 3, which then feeds the parcels onto the feeder conveyor at position 4
- **Manual:** Operators reach into position 5 & 6, then manually puts parcels onto position 7 & 8
- **Poly Slow:** Positions 5 & 6 automatically inject parcels at low tempo to gaps in positions 7 & 8 prior to operator. No reaching required
- **Poly Fast:** Positions 5 & 6 automatically inject parcels at high tempo to gaps at positions 7 & 8 prior to operator. No reaching required
- **Fully Automatic:** Position 5 continuously inject packages to position 7. No reaching required

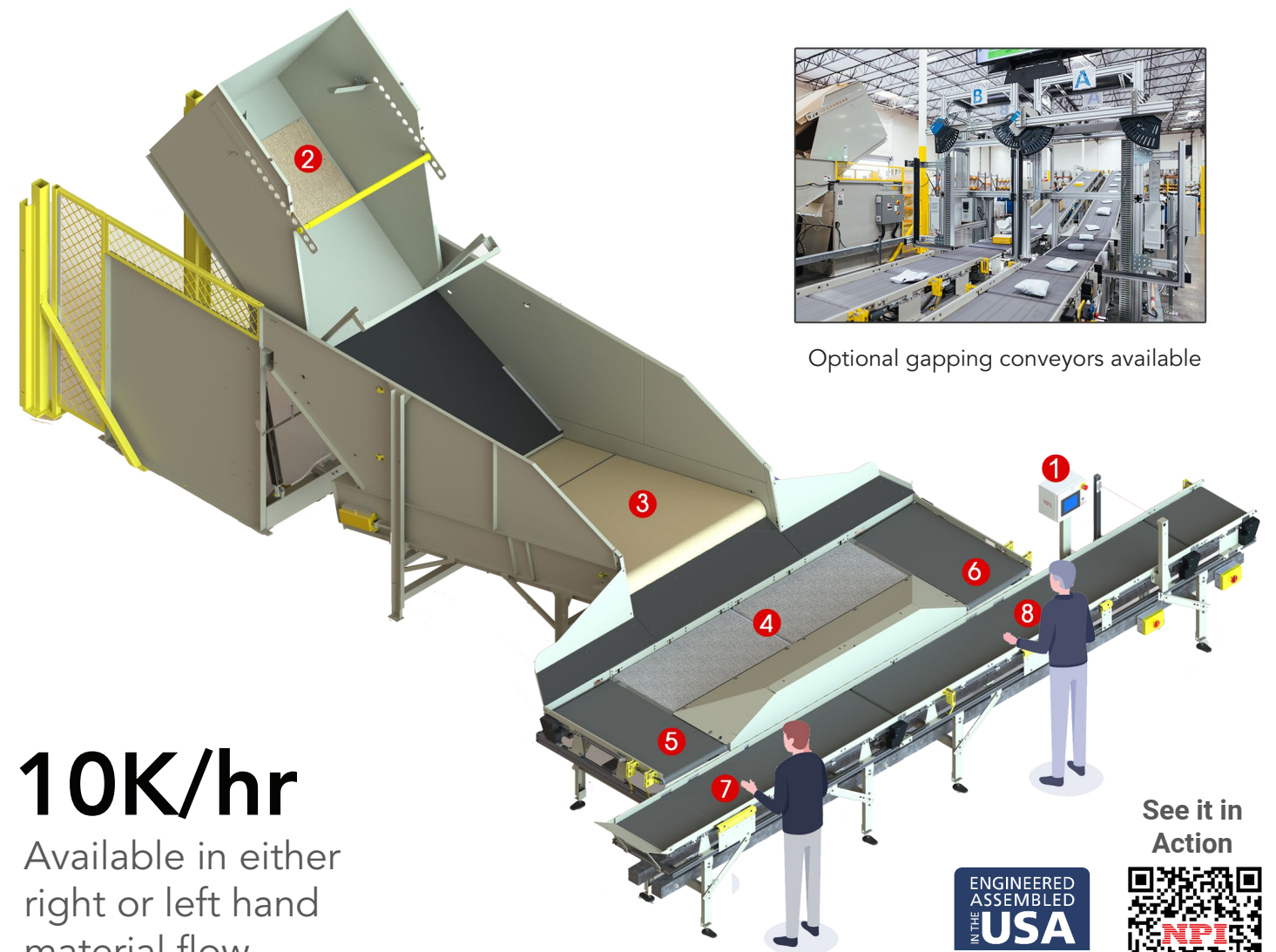

Optional gapping conveyors available

**10K/hr**

Available in either right or left hand material flow

See it in Action

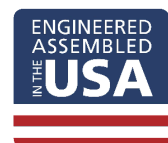

# Parcel Singulator

## Additional Information

- ✓ Converts parcel bulk flow into a single stream for high capacity product flow
- ✓ Provides a single system for handling flats, boxes, and poly bags
- ✓ Integration into existing warehouse solutions with efficient use of floor space
- ✓ Adjustable belt speeds means you can work at your own pace
- ✓ Can be utilized with one or two operators
- ✓ Integrated eStop system
- ✓ Runs in a variety of different modes that allows for singulation based on product
- ✓ Cost effective solution with small footprint
- ✓ Touch screen operator control panel

## Package Types



## Features

## Benefits

Intelligent Workload Balancing

Requires Fewer Operators

Selectable Singulation Modes

Set to Material Type

Touchscreen Operator Control Panel

Simple & Clear Operator Interface

Adjustable Belt Speeds

Define Operator Pace

Intelligent Feed Injection

Requires Less Operator Intervention

High Efficiency Servo Motors

Reliable and Accurate Processing

Programmable Logic Controller

Compatible W/ 3rd Party Equipment

Up to 10,000 Parcels Per Hour

High Throughput

Versatile Dumping Options

Dump Multiple Container Types

Patent Pending Pallet Hold Down Kit

Holds Pallets in Place While Tipping

+1 (888) 821-SORT - 14901 Trinity Blvd. Fort Worth, TX 76155

sales@npisorters.com - www.npisorters.com



AN IRVING-CLOUD COMPANY

PACKAGING SOLUTIONS | PROCESSING SOLUTIONS | MATERIAL HANDLING SOLUTIONS | SUPPORT

www.duravant.com