

Sort Up to 24,000 Parcels Per Hour

- ✓ Sorts up to 24,000 parcels/hour
- ✓ Sorts polybags, flats, boxes, and irregular packages
- ✓ Compact NPI Parcel Singulator for induction/singulation
- ✓ Accurately sorts parcels into sacks, carts, slides, or gaylords
- ✓ Monitor operations remotely with Duravant ONSIGHT™
- ✓ In-motion DWS with legal-for-trade capabilities
- ✓ High-density dual-sided design enables more destinations in a small footprint

Xstream

Dual Lane Sortation System



Sort Up to 10,000 Parcels Per Hour

- ✓ Sorts up to 10,000 parcels/hour
- ✓ Uses as little as 2,500 sqft of space
- ✓ Sorts polybags, flats, boxes, and irregular packages
- ✓ Compact NPI Parcel Singulator for induction/singulation
- ✓ Accurately sorts parcels into sacks, carts, slides, or gaylords
- ✓ Monitor operations remotely with Duravant ONSIGHT™
- ✓ In-motion DWS with legal-for-trade capabilities
- ✓ Dual-sided design maximizes destinations in a small footprint

Xstream Compact

High Density Sortation System

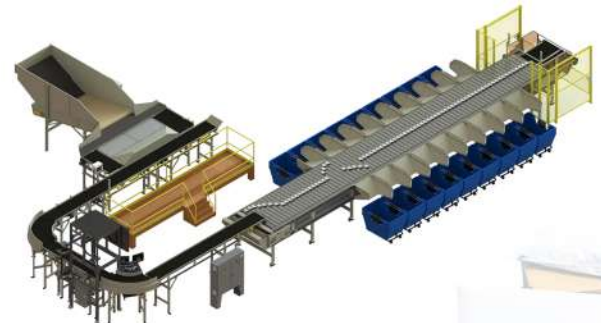

Singulate Up to 10,000 Parcels Per Hour

- ✓ Inducts/singulates up to 10,000 parcels/hour
- ✓ Unloads various container types
- ✓ Choose from different 4 work modes
- ✓ Operates with 1 or 2 operators
- ✓ Converts parcels into a single stream for efficient flow
- ✓ Singulates polybags, flats, boxes, and irregulars
- ✓ Integrates with third-party equipment
- ✓ Cost-effective, compact singulation solution
- ✓ Unloads brick-stacked boxes with pallet hold-down kit

Parcel Singulator

Induct & Singulate Parcels

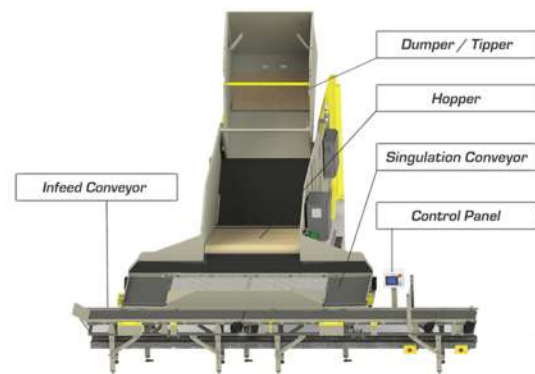

Sort Up to 20,000 Letters Per Hour

- ✓ Sorts up to 20,000 letters/hour
- ✓ Industry-leading MLOCR with handwriting recognition
- ✓ Omnidirectional barcode reader for IMB, 2D, and linear codes
- ✓ Patented anti-jam sorter pocket design
- ✓ Ergonomic pocket options available
- ✓ New Optesuite analytics software
- ✓ Configurable for inbound/outbound mail
- ✓ Handles letters and flats up to 0.25" thick
- ✓ Direct drive system lowers power use, downtime, and noise
- ✓ Best-in-class pickoff accuracy

Omega

Compact Letter & Flat Mail Sorter



Sort Up to 24,000 Letters & 18,000 Flats Per Hour

- ✓ Throughputs: 24,000 letters, 18,000 flats/hour
- ✓ Sorts flats up to 0.6" thick
- ✓ Industry-leading MLOCR
- ✓ Omnidirectional barcode reader for IMB, 2D, and linear codes
- ✓ Patented anti-jam technology
- ✓ Advanced sweepless chute design
- ✓ Best-in-class pickoff accuracy
- ✓ Direct drive system lowers power use, downtime, and noise

Vsort

High Volume Flat Mail Sorter



Sort Up to 50,000 Letters Per Hour

- ✓ Sorts up to 50,000 pieces/hour
- ✓ Configurable with 1,000 pockets
- ✓ Industry-leading MLOCR
- ✓ Omnidirectional barcode reader for IMB, 2D, and linear codes
- ✓ New Optesuite email and analytics software
- ✓ Processes heavier marketing mail reliably
- ✓ Patented anti-jam pocket design
- ✓ Ergonomic pocket options
- ✓ One or multiple levels, single or dual-sided
- ✓ Best-in-class pickoff accuracy

Maxim

High Volume Letter Mail Sorter

